



Research on Improving the Community Group Buying Model with Big Data Technology

Xinjia Zhuang

Accounting Department of Wuhan University of Technology, Wuhan, Hubei, China
1730537068@qq.com

Abstract

In recent years, community group buying has developed rapidly and competition in the market is fierce. The government's restrictions on corporate price wars have caused the development of community group buying platforms to stagnate, and there is an urgent need for reasonable optimization of the model. In the Internet trading platform, big data technology can play a good role in promoting the transaction and development of the platform, and help the development of the platform. This article mainly analyzes the current model of community group buying and its drawbacks, and explores the application methods of big data technology from the perspective of the target market, the supply chain, and the personalized demand. And it optimizes the mode of setting self-pickup points with a weighted algorithm in a simulated situation. Finally, it provides many suggestions for community group buying companies.

Key words— *Big data technology, community group buying, Internet platform, simulation experiment, model optimization*

1. INTRODUCTION

At the beginning of 2020, the community group buying model that was previously unconcerned was quickly pushed to the forefront due to the impact of the epidemic, and more and more consumers chose community group buying platforms for shopping. When many giants seized the community group buying market, the General Administration of Community Supervision came forward to stop the market chaos that companies use price wars to monopolize. As a result, community group buying companies can no longer rely on price wars for market occupation and their own development, and need to improve their original business models.

In the era of big data, more and more Internet companies try to use big data technology to improve their business models. However, community group buying has less use of big data technology. In the past, they established monopoly business models by using capital for price advantages, while ignoring the impact of model improvements. Therefore, using big data technology to collect data and statistical analysis of consumers to find the shortcomings of the existing business model, and rationally using big data technology in the new model to assist its own development, have become the current development methods for community group buying companies.

2. INTRODUCTION AND DEVELOPMENT STATUS OF COMMUNITY GROUP BUYING

2.1. Introduction to Big Data Technology

Big data is high-value information collected and organized from massive amounts of information data. It has the characteristics of huge volume, various types, accuracy, and fast processing speed. Big data technology collects big data from massive amounts of information to obtain truly valuable information. This technique analyzes data and draws valuable conclusions, and uses these conclusions to solve problems and improve existing models.

In the Internet transaction platform, big data technology can collect consumer's characteristics, needs, consumer preferences and other information through the Internet. At the same time, it can also increase consumers' purchase probability by pushing consumers information that meets the demand of consumers. In addition, big data technology can also collect information on commodity supply, logistics supply, and consumer reviews. And on the basis, the entire model will be promoted and therefore developing the existing model.

2.2. Brief history of community group buying

Community group buying means that people living in the same community order the daily necessities they need through the profession of "group leader". It is a shopping behavior initiated collectively by community residents in the form of group buying.

Community group buying originated in Changsha, Hunan Province in 2016.^[1] It was originally explored by e-commerce companies and tried to display products in WeChat groups. In 2017, with the rise of WeChat Mini Programs, some merchants transferred their operation centers to WeChat Mini Programs, resulting in an increase in the types of products. In 2018, community group buying was gradually recognized by most community residents.^[2] In the same year, many e-commerce companies entered the market, and community group buying officially entered a stage of rapid development. According to the "Research Report on China's Social E-commerce Industry in 2019", the industry size of community group buying in 2018 reached nearly 7.4 billion.

2019 is the stage of integrating the community group buying market. Many companies had poor operating conditions due to fragile supply chains and reduced customer sources. Community group buying companies had encountered large-scale mergers. With the outbreak of COVID-19 in 2020, community residents went out less and their shopping channels were blocked. Therefore, the model of community unified procurement and distribution has gradually become popular, and community group buying has ushered in a new round of explosive growth.

3. BUSINESS MODEL AND DISADVANTAGES

3.1. Community Group Buying Model

1) Business model. "Group-buying pre-sale + next-day store pick-up", that is, the user places an order through the mini programs and APPs, and then the platform informs the supply chain to deliver the goods to the community leaders' pick-up points, and the users pick it up from the leaders the next day.

2) Warehouse distribution model: Different from the self-operated pre-warehouse model of fresh food e-commerce, the community group buying platforms adopt a multi-level warehouse distribution model, which is generally called "shared warehouse-central warehouse-grid warehouse".^[2] The suppliers supply goods to the shared warehouse in advance. Every night after the platform cuts the order, the goods of sold quantity are delivered to the central warehouse. The overall sorting is carried out in the central warehouse based on the customers' area, and the goods are delivered to the grid

warehouse. Finally, the goods are sorted in the grid warehouse and delivered to the group leader's self-pickup points. After the group leaders receive the goods, they inform the consumers to pick up the goods.

3) Profit model. Suppose the profit is w , the number of order users is Q , the order frequency is f , the unit price is P , the number of pieces is N , the gross profit is G , and the operating cost is T . The community group purchase profit is shown in (1).

$$W = Q \times F \times P \times N \times G - T \quad (1)$$

This formula reflects the capabilities required by the community group buying platform, including user promotion, contract fulfillment capabilities, supply chain, scale and supplier control.

Suppose the total profit per customer is w , the unit price of per customer is p , the gross profit margin of per customer is g , the cost of fulfilling the purchase agreement is t_1 , the number of buying orders is q , and the cost of acquiring per customer is t_2 . The profit of a single user is shown in (2).

$$w = (p \times g - t_1) \times q - t_2 \quad (2)$$

3.2. Disadvantages

1) It is difficult to complete the last mile of delivery. The business model of community group buying and the warehouse distribution model lead to its inherent drawbacks. Community group buying adopts a multi-level warehouse allocation model, that is, customers place an online pre-sale order, and then the platform sends the goods to the group leader the next day according to the predetermined order, and finally the customers pick it up. This model can certainly reduce costs and performance costs, but at the same time, compared with the "order + flash delivery" of the self-operated front warehouse, the delivery timeliness is greatly reduced, and it cannot meet the immediate needs of customers.^[4] At the same time, customers are more inclined to the convenience and speed of delivering products home, so the last mile difficult problem of community group buying will be magnified.

2) The homogeneity is serious, and it is difficult for each platform to have its own bright spots. Nowadays, the number of community group buying platforms is increasing year by year. However, the product structure of each platform is similar, and it is difficult to reflect its own uniqueness. Therefore, it is easy to give users a feeling of "buy on any platform". Each platform is unable to provide personalized services and lacks core competitiveness.

3) The supply chain problems are highlighted. Based on the characteristics of community group buying of next-day delivery, the supply chain is facing great challenges. If fresh food is introduced with high

frequency in summer, it will cause huge loss and preservation problems, which will cause huge purchase cost and storage cost. However, if you do not buy enough fresh food, it will cause out-of-stock costs and a credit crisis. Secondly, whether the supply chain system is efficient or not is the decisive factor that determines the long-term development of an enterprise. Companies that do not have the support of a mature supply chain will inevitably decline in competition, and will eventually disappear in the history of community group buying.

4. COUNTERMEASURES-TAKE THE USE OF BIG DATA TECHNOLOGY AS THE MAIN PREMISE

4.1. Determine the target market.

The community group buying platform can use its own development strategy as the background and analyze the behavior and habits of community users through big data, so as to segment the community group buying market.^[5] When positioning the market and determining the target market, the community group buying platform should carry out large-scale and vigorous marketing campaigns to the user groups in the target market to attract these users. If multiple target markets are selected for development, or the most suitable target market cannot be determined, the community group buying platform should allocate marketing resources reasonably. The platform should step by step to test the preferences of the people in each target market, and try to attract users who are the most suitable for using its own platform, rather than arbitrarily consuming resources for meaningless publicity. In this way, the platform can increase customer stickiness and loyalty, and make good use of big data technology.

4.2. Optimize the supply chain.

The supply chain issue is a decisive factor for the rapid and continuous development of community group buying. Especially for fresh products, because the supply chain involves many links-productions--transportation, loading, unloading, packaging and circulation, errors in any link will have a huge impact on the supply chain.^[6]

At present, the supply chain of community group buying mainly adopts a three-level warehouse allocation model called "shared warehouse-central warehouse-grid warehouse". The community group buying platform transports the goods provided by the supplier to the shared warehouse, and the goods in the grid warehouse are transported to their respective pick-up points, and then the residents themselves pick up the goods. Through big data technology, the community group buying platform can study the links of the supply chain according to the consumers' evaluation of the goods in a certain area, and then analyze the situation of the supply chain. Later,

through the horizontal comparison of multiple regions, a problematic supply chain can be effectively judged. So that the operation center can infer the problematic link based on the results of big data analysis. Finally, adjust and optimize the links of the supply chain based on the above analysis results.

4.3. Meet individual needs.

The community group buying platform can adjust different types of products on the purchase page to meet the individual needs of users.^[7]

The community group buying platform should analyze the characteristics of the keywords in the search bar of consumers. To be precise, it is to vectorize the collected data, and each dimension of the vector is composed of its feature items and weight values. The weight is calculated using the TF-IDF method, and the calculation formula is as (3).

$$w(t_i, d) = \frac{t_f(t_i, d) \times \log\left(\frac{N}{n_i} + 0.01\right)}{\sqrt{\sum_{t_i \in d} \left[t_f(t_i, d) \times \log\left(\frac{N}{n_i} + 0.01\right) \right]^2}} \quad (3)$$

Among them, $w(t_i, d)$ is the weight of t_i , d is the set of all search results, $t_f(t_i, d)$ is the frequency of t_i appearing in all search results, N is the total number of all search results, and n_i is the number of times t_i appears in all search results. Through big data collection and analysis and calculation, the platform can find the words that each user can search frequently in the short term. In this way, the platform can recommend products to the user to increase the user's buying probability. In the same way, the platform can make big data analysis of products purchased by users in the past, keywords and user reviews of products browsed by users. Here are a few suggestions envisaged.

1) For daily necessities, the community group buying platform can grasp the consumption habits and consumption ability of community users through big data crawling, and match products with users according to information such as the price and quality of the goods, thereby establishing personal demand orders. Therefore, the platform can display the products in the personal demand order on the purchase page, and issue special offers for some of the products.

2) For fresh food, the community group buying platform can use big data to grasp the user's life habits, such as the dishes that they usually eat and the dishes that are often repurchased, so as to personalize the launch of the "Today's Recipe" with links of the fresh food and cooking methods and nutritional value.

3) For other products, the community group buying platform can monitor the products purchased online on this platform or other platforms through big data

technology, and then infer the "favorite" products that meet personal consumer psychology and preferences. After this, the platform can push the products in "Guess you like" by promotional videos, other user reviews, and Internet celebrities' experience.

4.4. Use weighting algorithm to reasonably set self-pickup points

At present, when each community group buying platform sets up self-pickup points around the community, it generally only considers the shortest straight line distance from the residential building. This method has incomplete analysis and large randomness, which easily causes residents with a large purchase volume to spend a longer time and a longer distance to pick up the goods. This article uses simulation experiments to demonstrate new calculation methods to help community group buying platforms to set up self-pickup points around the community more reasonably. The simulation experiment is as follows.

Now simulate a community of 25 residential buildings, the buildings in the community are arranged in a square. There are 25 residential buildings from a_1 to a_{25} , and 1, 2, 3, and 4 are the self-pickup points outside the gates of the four communities in the southeast, northwest and north. The distance between the two residential buildings on the connecting line is set to 1, and the distance between the pick-up point and the nearest residential building is 1.

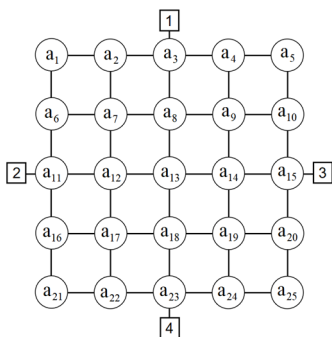

Figure 1. Simulated residential building

The random function in python language was used to simulate the average daily purchase volume of 25 residential buildings in the community, and the unit is kg. To facilitate calculations, take integers. The compiled code is as follows.

```
import numpy as np
import random
s= np.array([[random.randint(10, 100) for i in range(5)] for j in range(5)])
result = s.T
print(result)
```

Figure 2. Simulated residential building

The output is as follows.

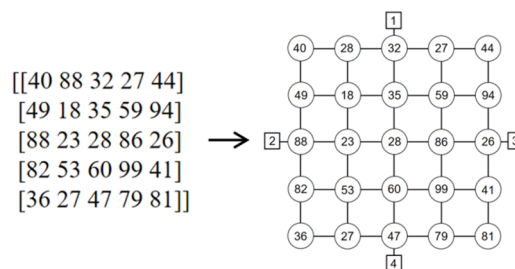

Figure 3. output result and schematic diagram of residential building after substitution

Suppose that the sum of the physical strength required by the residents to pick up the goods from the pick-up point to their own building is S , then the expression of S is (4).

$$S_j = \sum_{i=1}^n w_i \times \text{mind}(i, j), n = 25, j \in (1,4) \quad (4)$$

For example, S_1 represents the calculation result of self-lifting point 1, S_2 represents the calculation result of self-lifting point 2, and so on. The total weight of the goods in the a_i building is w_i , and the $\text{mind}(i, j)$ represents the minimum distance from the a_i building to the pick-up point j . Since the distances of the community group buying platforms are currently measured by satellite positioning, this simulation experiment only simply sets the route and distance to simplify the calculation and fit the actual situation.

According to the data and calculation formula obtained by the random function, $S_1=5785$, $S_2=5558$, $S_3=5135$, $S_4=5229$. Therefore, in the simulation experiment, choosing to set up self-pickup points in 3 places is most conducive to the residents of the community to pick up goods.

This method and the simple distance comparison method are more reasonable for the setting of self-pickup points. It pays more attention to the users' feelings and avoids that the self-pickup point is set too far, causing residents who buy more goods to travel a long distance. This can further enhance the residents' sense of experience.

In actual use, the community group buying platform can use big data technology to collect and analyze the consumption of residents in each community on this platform. The platform uses information such as consumption frequency, consumption price, and the weight of purchased goods to form a data set of each inhabitant. After that, the consumption level of each resident is fitted by the big data algorithm as the weight in the algorithm, and the distance of the residents to the simulated self-pickup point is multiplied to obtain the value of each pick-up point. Finally, after the comparison, the optimal simulated self-pickup point is selected as the self-pickup point of the cell.

5. CONCLUSION

With the development of the times, community group buying has a broad space for development. But at this stage, the community group buying model has its own drawbacks. If a company wants to stand out among the many communities based on group buying platforms, it must make rational use of big data technology to make analysis and innovative decision-making in terms of logistics supply chain, user's personalized needs, and self-pickup point settings. After improving the algorithms and models of data analysis, companies need to re-innovate and optimize business models, enhance their competitiveness, and promote their own rapid development.

REFERENCES

- [1] Zheng, Y. (2021) Analysis of Community Group Buying Marketing Model and Exploration of Development Strategy. *Rural economy and science and technology*.2021,32 (12): 95-97.
- [2] Zhang, J. (2021) Analysis on the Development Strategy of Community Group Buying. *Modern Marketing (Academy Edition)*. 2021, (07): 80-81
- [3] Wei, Y.H. (2021) How to regulate monopolistic behavior in community group buying. *Market Weekly*. 2021, 34(07):168-171
- [4] Zhang J.H., Wang Z.Y., Gao L.Y. (2021) Exploration on the development strategy of community group buying mode under the new retail background. *Business News* .2021, (18): 160-161
- [5] Liu, L.Q. (2021) Optimization of Group Purchase Service Mode in E-commerce Community in Big Data Era. *Electronic Business*, 2021, (18): 54-56.
- [6] Pan, Y. (2021) Optimization of Fresh Food Supply Chain Based on "New Retail". *Times Finance*. 2021, (18): 71-73
- [7] Song, L.H. (2020) Analysis on Consumers' Choice Behaviors of Group-buying E-commerce Platforms in the Network. *Economy Modern Marketing (Business Edition)*. 2020, (10): 156-157
- [8] Chinaindexacademy (2021) The natural home of property service enterprises-community group buying. *China Real Estate* .2021, (20): 57-59.

Open Access This chapter is licensed under the terms of the Creative Commons Attribution-NonCommercial 4.0 International License (<http://creativecommons.org/licenses/by-nc/4.0/>), which permits any noncommercial use, sharing, adaptation, distribution and reproduction in any medium or format, as long as you give appropriate credit to the original author(s) and the source, provide a link to the Creative Commons license and indicate if changes were made.

The images or other third party material in this chapter are included in the chapter's Creative Commons license, unless indicated otherwise in a credit line to the material. If material is not included in the chapter's Creative Commons license and your intended use is not permitted by statutory regulation or exceeds the permitted use, you will need to obtain permission directly from the copyright holder.

