

# Designing and Developing Electric Squeezer Machine for Mangrove Syrup Production

Lila Yuwana<sup>1,\*</sup> Suyatno<sup>1</sup> Susilo Indrawati<sup>1</sup> Alfi Tranggono Agus Salim<sup>2</sup> Sudarsono<sup>1</sup>  
Niniet Indah Arvitrida<sup>3</sup>

<sup>1</sup>Department of Physics, Institut Teknologi Sepuluh Nopember, Surabaya, Indonesia

<sup>2</sup>Department of Mechanical Engineering, Politeknik Negeri Madiun, Madiun, Indonesia

<sup>3</sup>Department of Industrial Engineering, Institut Teknologi Sepuluh Nopember, Surabaya, Indonesia

\*Corresponding author. Email: lila@physics.its.ac.id

## ABSTRACT

Generally, syrup production requires press machine to minimise time production. This paper reports detail design and construction of mangrove fruit press for syrup production purpose. The previous survey of syrup production in Wonorejo Rungkut Surabaya indicated that time production took a long duration of time. We propose a new design and development of mangrove fruit press that is able to reduce time production, therefore capacity of production in a day can be increased. Moreover, the calculation press machine dimension to obtain optimal production capacity and time consumption. Finally, the optimisation of fruit press yields the dimension of cross section of press is 32 cm and the power of electric motor to drive the squeezer is 1.5 HP. Interestingly, the time production to press Mangrove fruit can be reduced time consumed in pressing process significantly, i.e. one sixth from conventional process. Hopefully, this machine can improve the efficiency of Mangrove syrup production.

**Keywords:** Mangrove fruit, fruit press machine, mangrove syrup

## 1. INTRODUCTION

Surabaya, the second-largest city in Indonesia after Jakarta, has a lot of mangrove forest along east coast. The most fruit found in the area is mangrove apple (*Sonneratia caseolaris*) [1]. Notoriously, mangrove apple cannot be consumed without any preparation. However, this fruit can be processed into various food products (e.g. cakes and pudding) and syrup [2]. Interestingly, syrup produced from mangrove apple, as known as mangrove syrup, has natural substances that contain macronutrient and various vitamin [3] that also could be used as anti-diabetic, anti-oxidant, and anti-cholesterol [2], [4], [5]. That is why, farmers that live near to the east coast of Surabaya keep maintaining the sustainability of mangrove forest. Furthermore, harvesting the mangrove apple is completely safe for mangrove tree. This is because harvesting activity is just waiting fruits fall to the ground or to the net that was previously installed under the tree [6], [7].

Syrup production requires at least 10 kg in a day for producing 70 bottles of 360 ml syrup. The production needs pressing peeled mangrove apple to turn out syrup. Currently, mangrove farmers use hand muscles to squeeze peeled fruits. Obviously, it demands a lot of

effort to complete the production process. This is because the duration time of squeezing 10 kg mangrove apple is 5 hours exclude the other steps of syrup production [8]. This hard works should be reduced significantly. Moreover, duration time of squeezing process has to be minimised.

Actually, to reduce time consumed for squeezing can be attain by using squeezer machine which is available in market. However, the reason why farmers do not apply this squeezer machine is the pressing process of mangrove apple requires specific criteria. The criteria to implement press machine could be noticed by the surveying small medium enterprise of syrup mangrove. Henceforth, we propose to design and develop a proper electric squeezer machine to attain the shortest time taken in squeezing process based on the survey and further calculation. The calculation aimed to determine the power of electric motor to drive the mechanical squeezer. The essential components to build the squeezer machine are electrical motor, hydraulic pump, and mechanical squeezer. Hopefully, the squeezer machine will be viable implemented by mangrove syrup producer to increase the production capacity in a day.

The next sections of this paper are constructed as follows. In Section 2, we describe methods to design and

develop electric squeezer machine. Moreover, results of the design and development of electric squeezer machine is performed in Section 3. Finally, the conclusion of the paper is concluded in Section 4.

## 2. METHOD

Mangrove trees in Surabaya are located near east coast. In addition, there is tourism place in near mangrove forest in Rungkut District. The location of our research was in mangrove forest in Rungkut District where the mangrove syrup producer exists. The position of mangrove forest and the location of syrup is depicted in Figure 2.

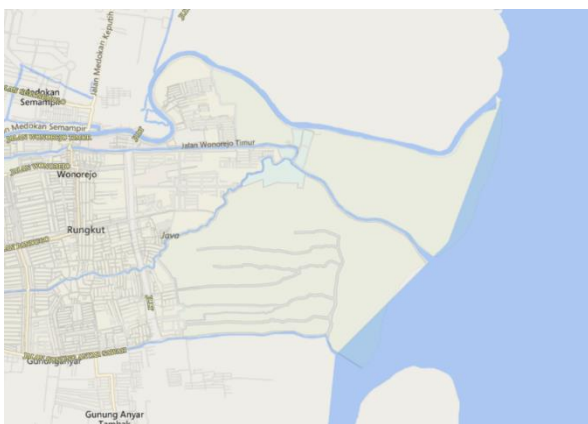

**Figure 1.** The location of mangrove forest and syrup production in Rungkut District [9].

The process of development of electric squeezer machine embraces survey, calculating, design, and construction. The detail of these steps is depicted in Figure 1.

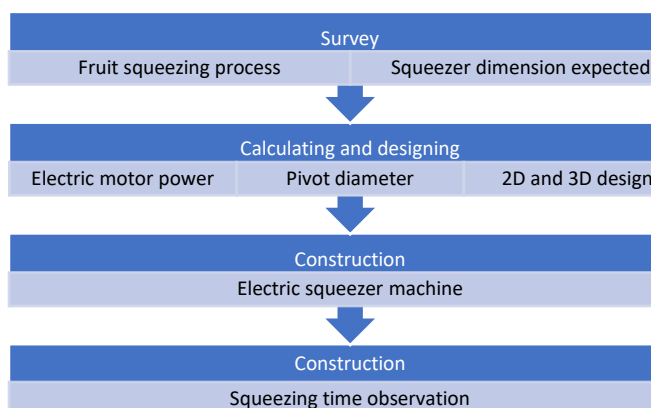

**Figure 2.** Main steps of development of electric squeezer machine

Figure 2 reveals several steps to develop and implement electric squeezer machine. Firstly, we have investigated syrup production process to examine requirements for developing the machine. The main equipment of the machine is electric motor, gear box, hydraulic pump, and squeezer machine. Next, we determine power of the electric motor, capacity of the hydraulic pump, and pivot diameter of electric motor and gear box. Furthermore, 2-dimensional and 3-dimensional design of electric squeezer are generated. Thirdly, we build the electric squeezer machine based on survey, calculation, and design. Finally, we perform trial process of pressing mangrove apple by utilising electric squeezer machine. While the machine is running, we observe time duration of pressing process of 10 kg mangrove apples. Obviously, all those mangrove fruits has to be prepared prior to the pressing process [8].

## 3. RESULT AND DISCUSSION

According to the survey, we notice that pressing step take the longest duration of time. This is because for squeezing 10 kg requires 5 hours excludes time consumed by other steps. This step also needs very hard effort because the pressing process is performed by bare hand (Figure 3).



**Figure 3.** Conventional way to squeeze peeled mangrove fruit.

The survey also reveals that pressing process needs hydraulic pump with a capacity of 15 tons. That is why we employ hydraulic pump 20 tons to ensure the pressing

process can be performed successfully. Next, we select the electric motor with power of 1.5 HP ( $P$ ), rotation of 7500 rpm ( $n_1$ ), and diameter of pivot electric motor is 3.5 cm ( $d_1$ ). Before we make further calculation, it is good idea to convert the units of HP into Watts (W) [10]. By using standard conversion  $P$  in Watts can be calculated as follows [11]

$$P = 1.5 \text{ HP} \cdot \frac{0.746 \text{ KW}}{1 \text{ HP}} = 1.1 \text{ KW}.$$

This transmission power ( $P$ ) is employed to drive hydraulic pump with the expected rotation speed is 10700 rpm. Therefore, rotation speed of electric motor,  $n_1 = 7500 \text{ rpm}$  has to be calculation increased into  $n_2 = 10700 \text{ rpm}$ . Considering this case, we use gear box to convert from  $n_1$  to  $n_2$  by selecting gear box pivot with specific pivot diameter based on this. Next, we calculate diameters of electric motor pivot and gear box pivot.

The ratio of reduced rotation is

$$i = \frac{n_1}{n_2} = \frac{7500}{10700} = 0.7$$

where

$$\frac{1}{i} = \frac{d_1}{d_2}.$$

Therefore,

$$d_2 = i \cdot d_1 = 0.7 \cdot 3.5 \text{ cm}$$

$$d_2 = 2.45 \text{ cm}.$$

Based on these calculations, we designed electric squeezer machine to decrease duration time of squeezing process significantly. The design is revealed in Figure 4.

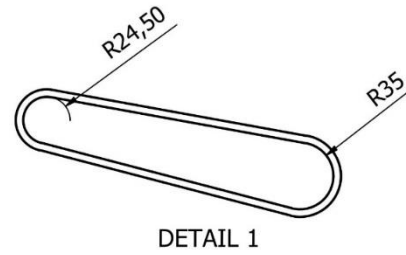
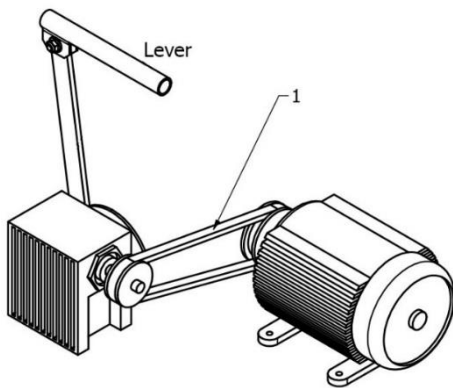
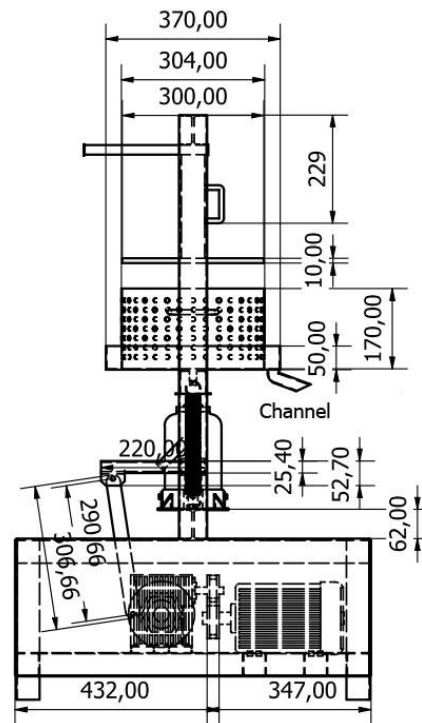
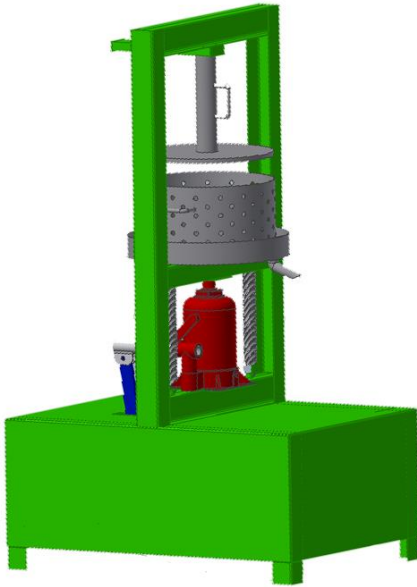

Figure 4. Electric motor pivot and gear box pivot.

Figure 4 shows the essential parts of electric squeezer machine, i.e. electric motor, gear box, belt, and lever. The process started from electric motor pivot. The belt guarantees gear box also makes rotation motion. Furthermore, gear box converts rotation motion into oscillation motion to drive hydraulic pump. Next, hydraulic pump lifts the piston until reach the static on the top. The liquid resulted from squeezing process is guided through the channel. The brief design to realise this process is shown in Figure 5.





**Figure 5.** Design of electric squeezer machine.

By using the design, we constructed the electric squeezer machine. The pressing process performed by this machine is completely similar as the conventional process. The construction of electric squeezer machine is depicted in Figure 6.



**Figure 6.** The electrical squeezer machine construction.

Next step, we observed the functional of the electrical squeezer machine, particularly in time consumed in

pressing process. Time consumed by this machine is 50 minutes to squeeze 10 kg mangrove apple, while it takes 5 hours or 300 minutes if the farmer uses conventional process. In other words, the using of electric squeezer machine can reduce time consumed in pressing time significantly, i.e. from 300 minutes to 50 minutes. Interestingly, syrup producer can increase the capacity of syrup production in a day, from 70 bottles to at least 140 bottles a day. Hopefully, by using this machine, mangrove farmers could attain a wide diversity of products processed from mangrove apple.

#### 4. CONCLUSION

In this paper, we have successfully performed the design and the development of the electric squeezer machine. The construction is obtained based on survey, observation, and calculation. Based on the survey, we have to provide hydraulic pump with capacity of 20 tons to perform pressing process in mangrove syrup production. Furthermore, we collect the beneficial information to be utilised for the improvement of pressing process. The electric squeezer machine constructed has transmission power of 1.1 KW to drive electric motor pivot and gear box pivot of 325 mm and 425 mm, respectively. The optimisation of fruit press yields the dimension of cross section of press is 32 cm and the power of electric motor to drive the squeezer is 1.5 HP. The machine is able to decrease time consumed in pressing process significantly, i.e. one sixth from conventional process. For instance, it can reduce time duration from 300 minutes to 50 minutes. Moreover, the production capacity could be increased at least to the double, e.g. from 70 bottles to at least 140 bottles a day. Hopefully, mangrove farmers will be able to advance diversity of processed mangrove apple.

#### REFERENCES

- [1] Wahyu Tjahjaningsih, Sapto Andriyono, Kustiawan Tri Pursetyo, "Analisis Potensi Sonneratia sp. Di Wilayah Pesisir Pantai Timur Surabaya Melalui Pendekatan Ekologi Dan Sosial-Ekonomi [Potency Analysis Of Sonneratia sp. At East Coast Surabaya Through Ecology And Social Economy Studies]," *J. Ilm. Perikan. dan Kelaut.*, vol. 5, no. 2, p. 129, Jan. 2013, doi: 10.20473/jipk.v5i2.11395.
- [2] A. C. Rahim and M. F. Abu Bakar, *Pidada—Sonneratia caseolaris*. Elsevier Inc., 2018.
- [3] R. D. E. Manalu, E. Salamah, F. Retiaty, and N.

- Kurniawati, “Kandungan Zat Gizi Makro dan Vitamin Produk Buah Pedada (*Sonneratia caseolaris*),” *Penelit. Gizi dan Makanan*, vol. 36, no. 2, pp. 135–140, 2013.
- [4] Jariyah, S. B. Widjanarko, Yunianta, T. Estiasih, and P. A. Sopade, “Pasting properties mixtures of mangrove fruit flour (*Sonneratia caseolaris*) and starches,” *Int. Food Res. J.*, vol. 21, no. 6, pp. 2161–2167, 2014.
- [5] M. A. Ovi, “The Mangrove fruit ( *Sonneratia Caseolaris* ),” no. October, 2015.
- [6] A. Saputra, “Ayo Rasakan Khasiat Sirup Bogem Mangrove Wonorejo,” *Jatim Now*, 2018.
- [7] S. E. Prasetyo, “Sumber Ekonomi Pantai Timur Surabaya, Sirup Dari Buah Mangrove,” *Jawa Pos*, 2017.
- [8] “Cara Membuat Sirup Mangrove Jenis Pedada (*Sonneratia caseolaris*) ~ BMC Mangroves.” <https://bmcuniversitasriau.blogspot.com/2016/08/cara-membuat-sirup-mangrove-jenis.html> (accessed Jan. 26, 2020).
- [9] “Peta RDTR Surabaya,” *DPRKPCKTR Surabaya*. <http://petaperuntukan.cktr.web.id/> (accessed Jan. 29, 2020).
- [10] I. K. Suarsana, “MESIN PRESS HIDROLIK SEMI-OTOMATIS,” 2016.
- [11] F. Hydraulics, *Hydraulic Formulary*. 2013.